

# Premium Water Heaters

The Albin Pump Marine Premium Water Heaters and square models have a toxic free ceramic inside coating to ensure highest water quality over time. Dual heating as standard - electrical heating and indirect heating based on an second heat source, for example based on the cooling system from the Marine engine or generator set.

- Round version 22 liter (5.8 gal), 30 liter (8 gal), 45 liter (12 gal), 60 liter (17 gal)
- Rectangular version 20 liter (5.6 gal)
- Interchangeable with common brands such as Webasto/Isotemp
- 850W, 230V or 800W, 120V
- Doubly enameled steel tank with aluminium outer coating
- Enameled iron heat exchanger for indirect heating from e.g. engine cooling water
- Incoloy corrosion-resistant alloy elements for electrical heating
- Heat loss 1 °C (1.8 °F)/hour over 24 hours
- Flexible mounting brackets, thermostat and drain valve are included
- Designed for continuous use onboard vessels in demanding environments



## Premium Rectangular Water Heater 20L

Part no.	Power	Capacity	Voltage	Fuse size	Connections	Dimensions LxWxH	Weight empty
08-01-005	850W	20 L (5.3 gal) Heats up 20L (5,6 gal) in 45min, good for 30L of mixed warm water or a 3 minute shower.	230V - 50 Hz	3.7 A	Fixed port connections BSP ½"	536 x 190 x 420 mm (21.1 x 7.5 x 16.5 in)	12.5 Kg (28 lbs)
08-01-028	800W		120V - 60 Hz		Fixed port connections NPT ½"		



## Premium Water Heater 22L

Part no.	Power	Capacity	Voltage	Fuse size	Connections	Dimensions LxWxH	Weight empty
08-01-001	850W	22 L (5.8 gal) Heats up 22L (5,8 gal) in 1h, good for 35L of mixed mixed warm water or a 3,5 minute shower.	230V - 50 Hz	3.7 A	Fixed port connections BSP ½"	423.5 x 390 x 404 mm (16.7 x 15.4 x 15.9 in)	11 Kg (24 lbs)
08-01-024	800W		120V - 60 Hz		Fixed port connections NPT ½"		



## Premium Water Heater 30L

Part no.	Power	Capacity	Voltage	Fuse size	Connections	Dimensions LxWxH	Weight empty
08-01-002	850W	30 L (7.9 gal) Heats up 30L (8 gal) in 1,5h, good for 45L of mixed warm water or a 4,5 minute shower.	230V - 50 Hz	3.7 A	Fixed port connections BSP ½"	503.5 x 390 x 404 mm (19.8 x 15.4 x 15.9 in)	12 Kg (26 lbs)
08-01-025	800W		120V - 60 Hz		Fixed port connections NPT ½"		



## Premium Water Heater 45L

Part no.	Power	Capacity	Voltage	Fuse size	Connections	Dimensions LxWxH	Weight empty
08-01-003	850W	45 L (11.9 gal) Heats up 45L (12 gal) in 2h, good for 65L of mixed warm water or a 6,5 minute shower	230V - 50 Hz	3.7 A	Fixed port connections BSP ½"	663.5 x 390 x 404 mm (26.1 x 15.4 x 15.9 in)	14 Kg (31 lbs)
08-01-026	800W		120V - 60 Hz		Fixed port connections NPT ½"		



## Premium Water Heater 60L

Part no.	Power	Capacity	Voltage	Fuse size	Connections	Dimensions LxWxH	Weight empty
08-01-004	850W	60 L (15.8 gal) Heats up 60L (16 gal) in 4h, good for 90L of mixed warm water or a 9 minute shower	230V - 50 Hz	3.7 A	Fixed port connections BSP ½"	823.5 x 390 x 404 mm (32.4 x 15.4 x 15.9 in)	16 Kg (35 lbs)
08-01-027	800W		120V - 60 Hz		Fixed port connections NPT ½"		

# Premium Water Heaters



## Premium Square Water Heater 22l

Part no.	Power	Capacity	Voltage	Fuse size	Connections	Dimensions LxWxH	Weight empty
08-01-032	850W	22 L (5.8 gal) Heats up 22L (5,8 gal) in 45min, good for 30L of mixed warm water or a 3 minute shower	230V - 50 Hz	3.7 A	Fixed port connections BSP ½"	493 x 320 x 320 mm (19.4 x 12.6 x 12.6 in)	11 Kg (24 lbs)
08-01-030	800W		120V - 60 Hz		Fixed port connections NPT ½"		

The Albin Pump Marine Premium Water Heaters and square models have a toxic free ceramic inside coating to ensure highest water quality over time. Electrical heating only.

- Interchangeable with common brands such as Webasto/Isotemp
- 850W, 230V or 800W, 120V
- Doubly enameled steel tank with aluminium outer coating
- Electric heating only 230V or 120V, for outboard boats or boats with genset, requires power AC 230V
- Incoloy corrosion-resistant alloy elements for electrical heating
- Heat loss 1 °C (1.8 °F)/hour over 24 hours
- Flexible mounting brackets, thermostat and drain valve are included

## Premium Electric Square Water Heater 22l

Part no.	Power	Capacity	Voltage	Fuse size	Connections	Dimensions LxWxH	Weight empty
08-03-032	850W	20 L (5.3 gal) Heats up 22L (5,8 gal) in 45min, good for 30L of mixed warm water or a 3 minute shower. Keeps heated water warm for a duration >10h when not connected to shore power.	230V - 50 Hz	3.7 A	Fixed port connections BSP ½"	493 x 320 x 320 mm (19.4 x 12.6 x 12.6 in)	11 Kg (24 lbs)
08-03-030	800W		120V - 60 Hz		Fixed port connections NPT ½"		

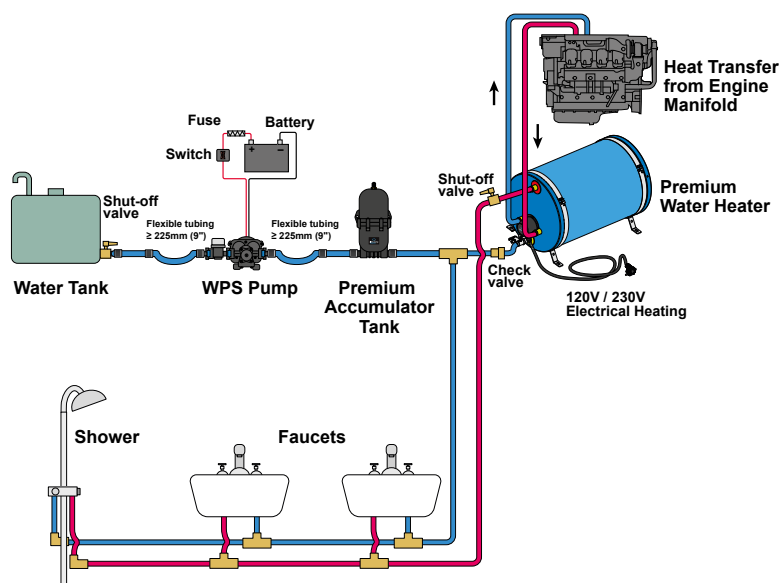

# Stainless Steel Water Heaters

The Albin Pump Marine Stainless Steel Water Heaters have a stainless steel AISI 316 tank, anti-corrosion treatment with pickling and passivation. Dual heating as standard - electrical heating and indirect heating based on a second heat source, for example based on the cooling system from the Marine engine or generator set.

- Round version 22 liter (5.8 gal), 30 liter (8 gal), 45 liter (12 gal), 60 liter (17 gal)
- Interchangeable with common brands such as Webasto/Isotemp
- 850W, 230V
- Enamaled iron heat exchanger for indirect heating from e.g. engine cooling water
- Incoloy corrosion-resistant alloy elements for electrical heating
- Heat loss 1 °C (1.8 °F)/hour over 24 hours
- Flexible mounting brackets, thermostat and drain valve are included
- Designed for continuous use onboard vessels in demanding environments

## Stainless Steel Water Heater 22L



Part no.	Power	Capacity	Voltage	Fuse size	Connections	Dimensions L x W x H	Weight empty
08-02-006	850W	22 L (5.8 gal) Heats up 22L (5,8 gal) in 1h, good for 35L of mixed warm water or a 3,5 minute shower.	230V - 50Hz	3.7 A	Fixed port connections BSP ½"	439.5 x 390 x 404 mm (17.3 x 15.4 x 15.9 in)	11 Kg (24 lbs)

## Stainless Steel Water Heater 30L



Part no.	Power	Capacity	Voltage	Fuse size	Connections	Dimensions L x W x H	Weight empty
08-02-007	850W	30 L (7.9 gal) Heats up 30L (8 gal) in 1,5h, good for 45L of mixed warm water or a 4,5 minute shower.	230V - 50Hz	3.7 A	Fixed port connections BSP ½"	503.5 x 390 x 404 mm (19.8 x 15.4 x 15.9 in)	12 Kg (26 lbs)

## Stainless Steel Water Heater 45L



Part no.	Power	Capacity	Voltage	Fuse size	Connections	Dimensions L x W x H	Weight empty
08-02-008	850W	45 L (11.9 gal) Heats up 45L (12 gal) in 2h, good for 65L of mixed warm water or a 6,5 minute shower	230V - 50Hz	3.7 A	Fixed port connections BSP ½"	689 x 390 x 404 mm (27.1 x 15.4 x 15.9 in)	14 Kg (31 lbs)

## Stainless Steel Water Heater 60L



Part no.	Power	Capacity	Voltage	Fuse size	Connections	Dimensions L x W x H	Weight empty
08-02-009	850W	60 L (15.8 gal) Heats up 60L (16 gal) in 4h, good for 90L of mixed warm water or a 9 minute shower	230V - 50Hz	3.7 A	Fixed port connections BSP ½"	849 x 390 x 404 mm (33.4 x 15.4 x 15.9 in)	16 Kg (35 lbs)

## Stainless Steel Water Heater 80L



Part no.	Power	Capacity	Voltage	Fuse size	Connections	Dimensions L x W x H	Weight empty
08-02-010	850W	80 L (21.2 gal) Heats up 80L (21,2 gal) in 5h, good for 120L of mixed warm water or a 15 minute shower	230V - 50Hz	3.7 A	Fixed port connections BSP ½"	1009 x 390 x 404 mm (39.7 x 15.4 x 15.9 in)	20 Kg (44 lbs)

# Accessories / Spare Parts



## Premium Water Heater Mixer Kit

Premium Mixer Kit, safe distribution of mixed warm water at exact temperatures.

- Allows you to not waste any hot water which saves water and energy

Part no.	Description
08-66-011	Premium Mixer Kit



## Hose Connection Kit

Part no.	Description
08-66-012	Hose Connection Kit



## Pressure Release Valve

Safely releases excess pressure and also for draining the water heater.

Part no.	Description
08-99-013	Pressure Release Valve



## Drain valve

Simplify the draining of the water heater of its water

- To avoid freezing or to preserve the water heater off season

Part no.	Description
08-99-014	Drain valve

## Replacement Heater Elements

Heater elements that fit all Albin Pump Marine water heaters

### Heater Element 550W / 500W

Part no.	Description	Type
08-99-015	Heater Element 230V 550W	550W allows to use the water heater at 230V with 4A shorepower fuse
08-99-018	Heater Element 120V 500W	500W allows to use water heater at 120V with 5A fuse



# Accessories / Spare Parts

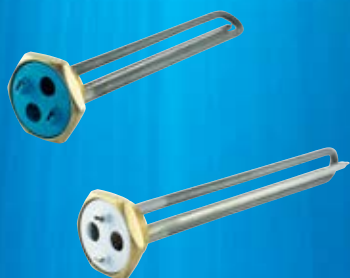

## Heater Element 850W / 800W

Part no.	Description	Type
08-99-016	Heater Element 230V 850W	850W allows to use water heater at 230V with 5A shorepower fuse
08-99-019	Heater Element 120V 800W	800W allows to use water heater at 120V with 10A shorepower fuse



## Heater Element 1250W / 1200W

Part no.	Description	Type
08-99-017	Heater Element 230V 1250W	1250W allows to use water heater at 230V with 10A shorepower fuse
08-99-020	Heater Element 120V 1200W	1200W allows to use water heater at 120V with 15A shorepower fuse



## Thermostat

Part no.	Description	Type
08-99-021	Thermostat to set temperature of heated water.	Adjustable 40° – 80° C (104° – 176° F)



## Premium Anode Short

Part no.	Description	Type
08-99-022	Short anode for Premium Water Heater	Premium Water Heaters 20 – 30 L (5.3 – 7.9 gal)



## Premium Anode Long

Part no.	Description	Type
08-99-023	Long anode for Premium Water Heater	Premium Water Heaters 45 – 60 L (11.9 – 15.8 gal)